Quantaray

by Sunpak

5.6" digital photo frame



Stock no. 81-166-0299

Opening Screen



Screen 2



View of back of the unit



Remote Control:

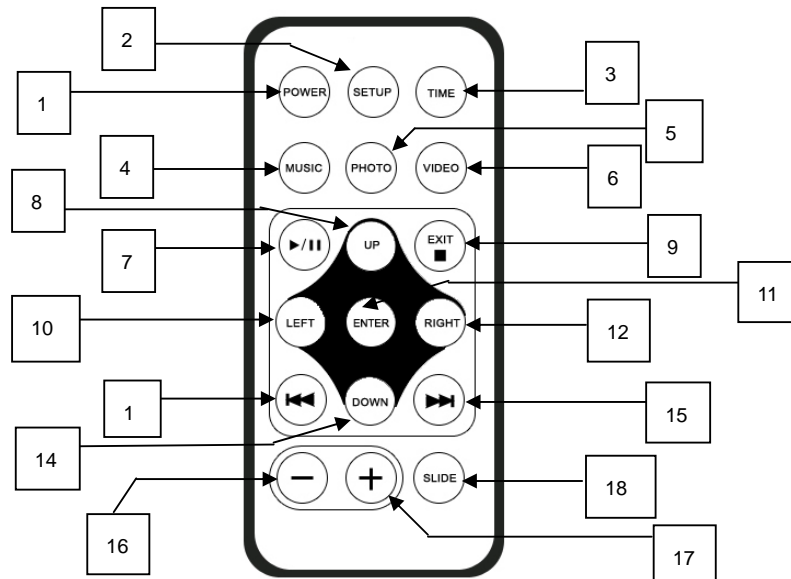

REMOTE CONTROL BUTTONS

1. POWER: Turns DPF on and off
2. SETUP: To activate On Screen Display settings
3. TIME: Displays calendar and time
4. MUSIC: Play music with a single press
5. PHOTO: Display thumbnails
6. VIDEO: Display video files
7. ▶/|| : Play/Pause
8. UP: Move up
9. EXIT/■ : Return to previous screen
10. LEFT: Move left
11. ENTER: Use to select highlighted item
12. RIGHT: Move right
13. ◀◀ : Previous
14. DOWN: Move down
15. ▶▶ : Next
16. - : Decrease volume
17. + : Increase volume
18. SLIDE: Slideshow

POWER UP

1. Connect the AC-DC adapter into the DC socket.
2. Press the power switch to the ON position. The unit will display the opening screen.



FAVORITE

Display two pictures at anytime.

1. When a photo is displayed on full screen, press the PHOTO button. Along with the photo a message appears on the bottom left side of the screen. "DON'T POWER OFF".
2. To activate this feature, select the FAVORITE option at the opening screen.

Note:

1. The zoom, rotate functions do not apply for the favorite photos.
2. Only pictures can be stored in FAVORITE function, the last picture saved will replace the prior picture.

PLAY PHOTO

1. Insert a memory card or USB driver that contains JPG image files into the card slot or USB port respectively.
2. Turn the digital photo frame ON.

Operate by using the remote control

- At the opening screen select CARD or USB you had inserted,
- Press the ENTER button, select the PHOTO icon or press the PHOTO key, then a series of thumbnail pictures will be shown on screen with background music if you have MP3 files in the card/USB drive.
- Select a photo with the UP/DOWN/LEFT/RIGHT button and press ENTER.
- Press ►► to display the next photo. Press ◀◀ to display a previous photo.
- For slideshow, press the SLIDE button.

PLAY MUSIC

1. Insert memory a card or USB driver that contains music files into the card slot or USB socket respectively.
2. Turn the digital photo frame ON.

Operate by using the remote control

- At the opening screen select CARD or USB you had inserted,
- Press the ENTER button, select the MUSIC icon or press the MUSIC key, then a list of available file names will displays on the right of screen; the first file will play automatically.
- Press the UP or DOWN key to highlight the file you want and then press the ENTER key to select.
- Press the SLIDE key to start a slideshow with your selected music.
- To pause/play press the ►/|| button.
- To stop the slideshow press the EXIT button to return to the opening screen.

PLAY VIDEO

1. Insert memory card or USB driver that contains video files into the card slot or USB socket respectively.
2. Turn the digital photo frame ON.

Operate by using the remote control

- At the opening screen select CARD or USB you had inserted,
- Press the ENTER button, select the VIDEO icon or press the VIDEO key, then a list of available file names will displays on the right of screen; The first file will be play automatically.
- To pause play press the ►/|| button
- To stop play press the EXIT button to return to the screen 2.

AUTO POWER ON/OFF

To activate these functions the setting times must be set to turn ON/OFF the unit. Enter POWER OFF sub-menu. Select the time setting and change to desired time for auto power off. Enter POWER ON sub-menu. Select the time setting and change to desired time for auto power on.



SET ALARM

Enter ALARM SETUP sub-menu and select the time setting. Change to desired time for alarm. To stop the alarm, press any key.

Note: Functions are only available when PHOTO, MUSIC or VIDEO is inactive.



USER SETTINGS

Entering and leaving the SETUP menu:

- (ii) Press the setup button on the remote control or the SETUP key at the rear of the unit to enter, press again to leave.

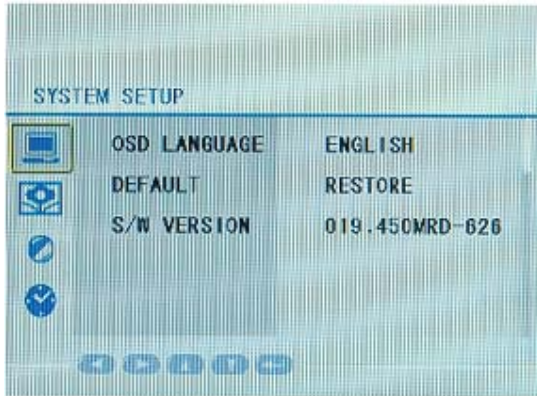

Entering and leaving the sub-menu and selecting options:

- (i) Navigate with the UP, DOWN, LEFT and RIGHT buttons on the remote or the buttons on the photo frame. Use the ENTER button to select.
- (ii) Press the exit button on the remote control or the exit button on the rear of the frame to leave the menu.



SYSTEM SETUP

On Screen Display Languages:

English, German, French, Portuguese.

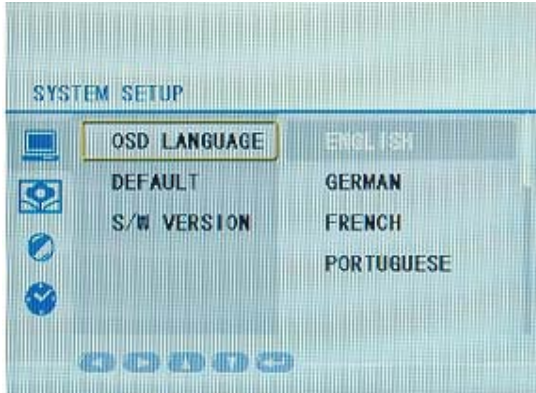

DEFAULT:

RESTORE – Restore factory settings

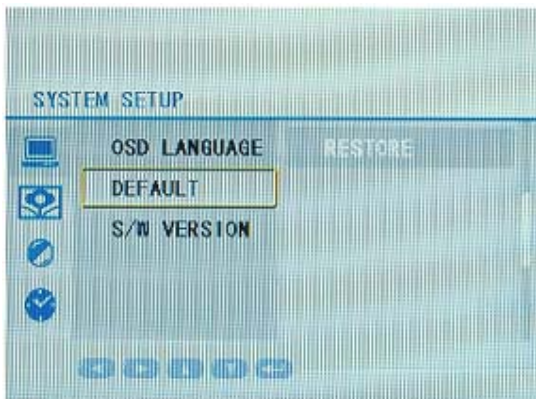

S/W VERSION:

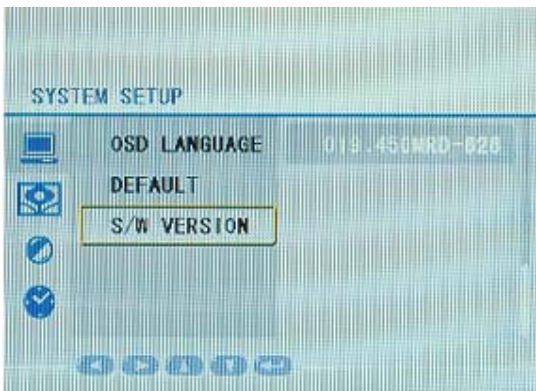
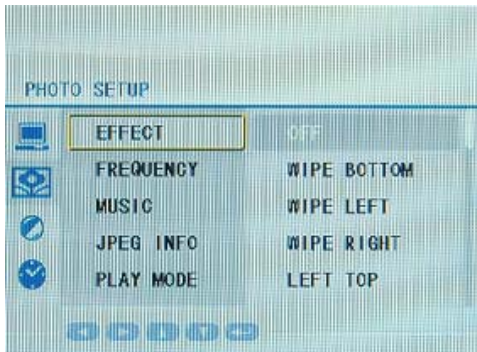

PHOTO SETUP

EFFECT:

OFF, WIPE BOTTOM, WIPE LEFT, WIPE LEFT, WIP RIGHT, LEFT TOP, RIGHT TOP, LEFT BOTTOM, RIGHT BOTTOM, EXTEND FROM H, EXTEND FROM V, COMPRESS TO H, COMPRESS TO V, WINDOW H, WINDOW V, WIPE TO CENTER, RANDOM, and WIPE TOP.



FREQUENCY: Time between photos

5 SECONDS, 10 SECONDS, 30 SECONDS, 1 MINUTE or 30 MINUTES

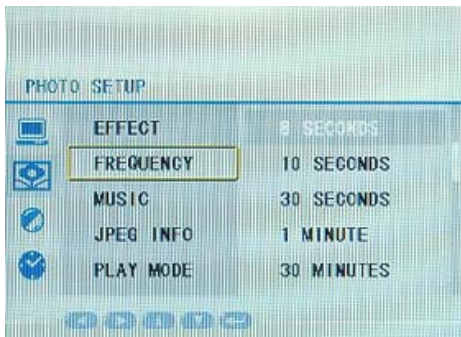

Music: Display music information: file name, size, and resolution.

ON/OFF

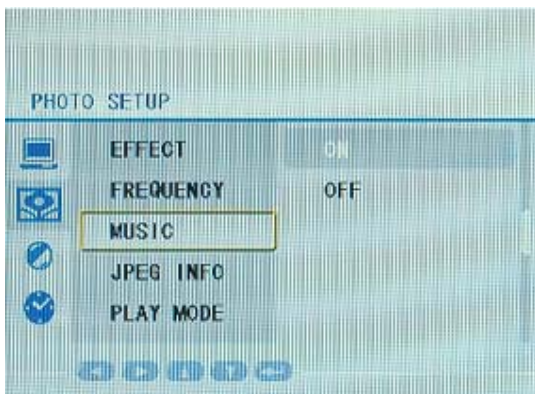

JPEG INFO: Displays photo information: file name, size, and resolution.
ON/OFF



PLAY MODE: Cycles through photos in sequence or in a completely random manner.
NORMAL/RANDOM

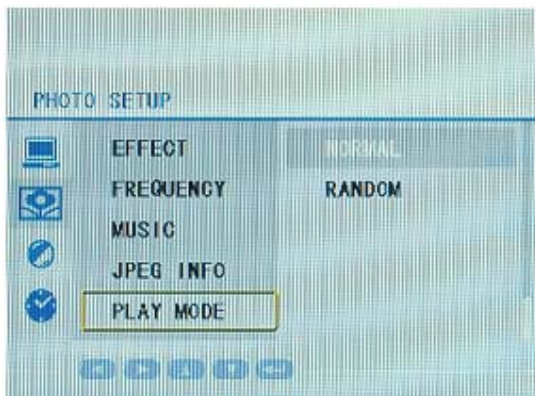

PICTURE SETUP (factory settings in brackets)

- BRIGHTNESS: 12 levels (6)
- CONTRAST: 12 levels (6)
- HUE: 12 levels, -6 to +6 (0)
- SATURATION: 12 levels (0)
- SHARPNESS: 8 levels (0)



CLOCK SETUP

DATE SETUP: Sets date (Year, Day, Month)

2000/01/08

TIME SETUP: Sets time (Military 24 hours)

13:28

ALARM SETUP: *(option for selected models only)*

19:30/OFF

POWER ON: Set to turn on automatically

08.00/OFF

POWER OFF: Set to turn off automatically

22:00/OFF

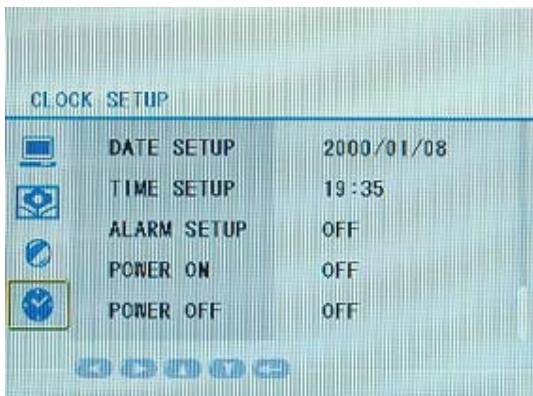

TECHNICAL SPECIFICATIONS

Support Cards/USB	Memory Stick®(MS), MultiMediaCard™(MMC), Secure Digital™ (SD), USB Flash Drives
Supported file formats	JPEG, BMP, MP3 and MP4
LCD Display	5.6"
Resolution	320 x 240
Viewing Modes	Full frame 4:3 Standard Aspect Ratio, Slide Show, Thumbnail Note: when displays 16:9 photos with top and bottom of screen darkened
Image Effects	Flip, Rotate, Zoom
USB Host (USB Port)	USB connects to mass storage devices (USB flash drives) via the USB connector.
Power Input	12V DC, 1.2A

REMARKS:

- 1) Unit does not support SDHC cards
- 2) Image information other than in the languages supported may be display incorrectly.
- 3) On power up the screen could take up to 5 seconds to become active.
- 4) The unit displays 4:3 photos in full screen. Photos not of this aspect ratio may have some areas of the screen displayed in black.

Frequently asked questions

1) Q: Can I use touch-enabled technology for my Digital Picture Frame?

A: The LCD screen does not support touch-enabled technology. Please use the buttons to control the Digital Picture Frame.

2) Q: If I keep showing the same photo for a long time, will it damage the LCD screen?

A: No. The Digital Picture Frame can display the same photo continuously for a long time. But it is recommended not to show the same picture continuously for more than 1 month.

3) Q: What is the best picture resolution displayed on the screen?

A: The frame's best resolution is 320 x 240.

47) Q: Does it play every type of AVI and or MPEG4 videos?

A: No. The device only works with the AVI and MPEG4 files taken by most digital cameras.

5) Q: How come the Digital Picture Frame does not show some of my photos?

A: The Digital Picture Frame is designed to show photos following the same camera industry standards format as digital cameras. This format is a JPEG format. Images, such as web images, scanned images, or photos in RAW format, are not stored according to camera industry standards and therefore cannot be displayed correctly on the Digital Picture Frame. You can use a PC application to convert such images into standard JPEG format before viewing them on the digital photo frame.

Maintenance and Precaution

- The digital photo frame is for indoor use only.
- To reduce the risk of fire or electric shock; do not expose this unit to rain or moisture.
- Do not block the ventilation holes on the back of the digital photo frame at any time.
- Keep your digital photo frame out of direct sunlight. Direct sunlight may cause damage. Do not attempt to open or repair of the digital photo frame. There is a risk of electric shock, and there are no user serviceable parts inside. Opening the case will void your warranty.
- Do not use the digital photo frame if conditions could allow condensation to occur, or damage may result.
- Your digital photo frame is a complex electronic device and cannot withstand excessive impacts or shocks.

Cleaning the LCD screen

- Treat the screen with care. The screen is a liquid crystal and can be easily scratched, broken or damaged.
- For fingerprints or dust we recommend using a soft, non-abrasive cloth such as a camera lens cloth to clean the LCD screen.
- If you use an LCD cleaning kit sold in a photo specialty store, apply the cleaning liquid to the cloth. Do not apply the liquid directly to LCD screen.

Replace the battery of the remote control:



1. Remove the battery compartment cover by pulling the cover in the direction of the arrow.

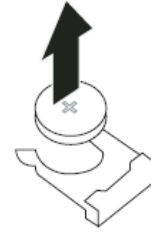

2. Remove the battery.

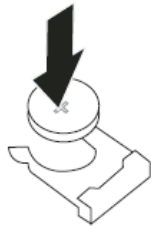

3. Insert the replacement battery taking note of the correct polarity (+/-).

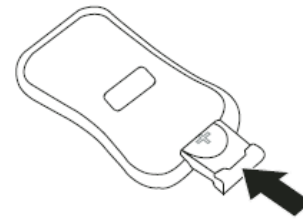

4. Replace the cover.

Regulatory Compliance

CE Declaration of Conformity

Attestation RSH05080201-1, RSH06080201-2

We declare under our responsibility that the product is in conformity with the following standards

EN55022:1998 (Radio Disturbance requirement of Information Technology Equipment)

EN55024:1998 (Immunity requirement of Information Technology Equipment)

EN61000-3-2:2000 (Limits for Harmonic Current Emission)

As assessed by the following applications standards:

89/336/EEC Electromagnetic Compatibility

This Product is produced by a manufacturing organization on ISO9000 level.

Federal Communications Commission (FCC) Notice (U.S. and Canada Only)

This equipment has been tested and found to comply with the limits for a Class B digital device, pursuant to Part 15 of the FCC Rules. These limits are designed to provide reasonable protection against harmful interference in a residential installation. This equipment generates uses and can radiate radio frequency energy and, if not installed and used in accordance with the instructions, may cause harmful interference to radio communications. However, there is no guarantee that interference will not occur in a particular installation. If this equipment does cause harmful interference to radio or television reception, which can be determined by turning the equipment off and on, the user is encouraged to try to correct the interference by one or more of the following measures:

-
- Reorient or relocate the receiving antenna.
 - Increase the separation between the equipment and receiver.
 - Connect the equipment into an outlet on a circuit different from that to which the receiver is connected.
 - Consult the dealer or an experienced radio/TV technician for help.

Changes or modifications not expressly approved by the party responsible for compliance could void the user's authority to operate the equipment.

Connections to this device must be made with shielded cables with metallic RFI/EMI connector hoods to maintain compliance with FCC Rules and Regulations.

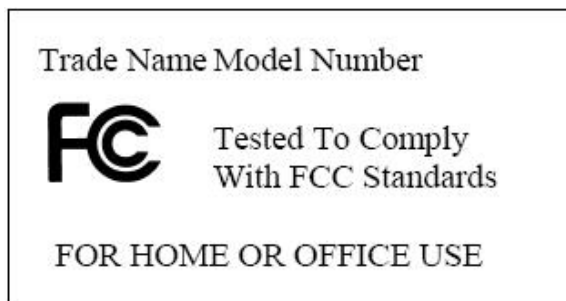

To prevent damage which may result in fire or shock hazard, do not expose this appliance to rain or excessive moisture.

THIS CLASS B DIGITAL APPARATUS MEETS ALL REQUIREMENTS OF THE CANADIAN INTERFERENCE-CAUSING EQUIPMENT REGULATIONS.

FCC Declaration of Conformity

This device complies with Part 15 of the FCC Rules. Operation is subject to the following two conditions:

(1) This device may not cause harmful interference, and (2) this device must accept any interference received, including interference that may cause undesired operation.

End-of-Life Disposal

Your new product contains materials that can be recycled and reused. Specialized companies can recycle your product in order to reuse components of the product and to minimize waste.

Please find out about the local regulations on how to dispose of your old unit from your local municipality.

(For Customers in Canada and U.S.A)

Dispose of in accordance to local state, provincial, municipal or federal regulations. For additional information on recycling in the U.S.A, contact www.eiae.org (Consumer Education Initiative)

Please find out about the local regulations on how to dispose of your old unit from your local municipality.

Quantaray by Sunpak
Tocad America Inc.
53 Green Pond Road
Rockaway, NJ 07866, USA
www.tocad.com